

TURBO 125FP (CE)



PLC control touch screen panel



Auto pad clean



Platform in / out movement
(Pad clean underneath)

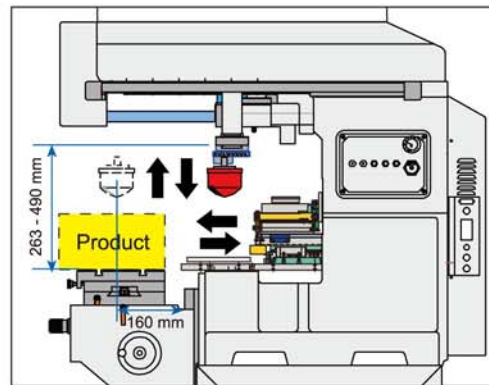

Maximum space for product/image with advantage of auto pad clean function

FEATURES

- Single color automatic pad printer
- Rigid aluminium cast machine frame
- Platform in/out movement
- Pneumatic power machine operation
- Use sealed ink cup set up
- Compatible with long life thin steel, polymer, 10 mm steel and laser ALP plates
- Dead-on printing plate registration for quick job change
- PLC control touch screen panel
- Automatic pad clean with programmable cleaning cycle
- Pad stroke & speed adjustment
- Special functions: double ink / print cycles, dwell and delay before print
- Digital pad stroke (DPS) for variable printing depth
- Hardened ground steel shaft with impregnated bushing ensure friction-free movement
- High speed and smooth machine operations

SPECIFICATIONS

Ink cup size :	Ø125, 130 mm
Printing plate size :	150 x 300 mm
Max. speed : (dry cycle) *	1,000 / hr.
Pad compression :	1,870N
Pad cylinder :	Ø63 mm
Pad carriage stroke (in/out) :	248 mm
Power :	110/220V
Air consumption :	228 litre/min. (approx.)
Accuracy +/- :	0.05 mm
Size : (L x W x H)	974 x 740 x 1,680 mm
Weight :	170 kg (approx.)

* Please note that actual output may be affected by print requirement, ink drying condition, load/unload arrangement, pad stroke speed, pad hardness, production setup, product quality and production control.

Milford Astor

Making your products speak for themselves
Australia's leading independent foil and Thermal Rubber company

www.astor.com.au

Sydney (02) 9663 3911

Melbourne (03) 9465 0166

Adelaide (08) 8234 5466

KENT
INTERNATIONAL

www.kentpp.com

085M-0608